



## Assembly Instruction

ITEM NO.: BF-CRA-Q

BF-CRA-F

BF-CRA-ET

QUEEN/FULL/TXL Power Head and Foot  
Adjustable Bed Frame with Massage, Zero  
Gravity, Charging ports and Nightlight



Please read the instructions carefully before installation and keep it in a safe place for future reference.

## PRECAUTIONS

1. Do not open or tamper with the transformer, control box, motors, or remote control (with the exception of battery compartments).
2. Immediately dispose of all packing materials as it can smother small children and pets. Do not allow any persons or pets under the bed. Children should not operate the bed without adult supervision.
3. Please consult your physician before using the massage feature if you have any health conditions you are concerned about, as the massagers may aggravate some conditions. Caution is especially advised for those with pacemakers, since the vibrating motion may cause the pacemaker to sense activity.
4. The bed lift motors are not designed for continuous use of more than 2 minutes in an 18-minute period, or approximately 10% duty cycle. Any attempt to circumvent or exceed this rating will shorten the life expectancy of the product.
5. The limitation is 750 lbs. The bed will structurally support these weights, provided it is evenly distributed across the head and foot sections. This product is not designed to support or lift this amount in the head or foot section alone. Exceeding this weight restriction could damage the bed and/or cause injury. Enter or exit the bed in a flat position and do not sit on the head or foot sections while in the raised position.
6. The level of sound experienced in a room is directly related to the environment within that location. In a room with hardwood floors and the massagers turned on, a vibrating noise can be noticeable. To reduce the resonance, place a piece of carpet or rubber caster cups under the legs. The rubber caster cups also prevent the bed from sliding when located on smooth or hard surface flooring.
7. Always unplug the base from the electrical outlet before cleaning or servicing the base. If the cord or plug is damaged, discontinue use of the bed base and contact qualified service personnel for examination and repair. Make sure the base is in a flat position, and the vibrating motors are off before unplugging from the power source.

**\* PLEASE BE SURE TO FOLLOW THE INSTALLATION STEPS IN THE MANUAL TO AVOID UNNECESSARY LOSSES CAUSED BY IMPROPER INSTALLATION.**

# Parts List

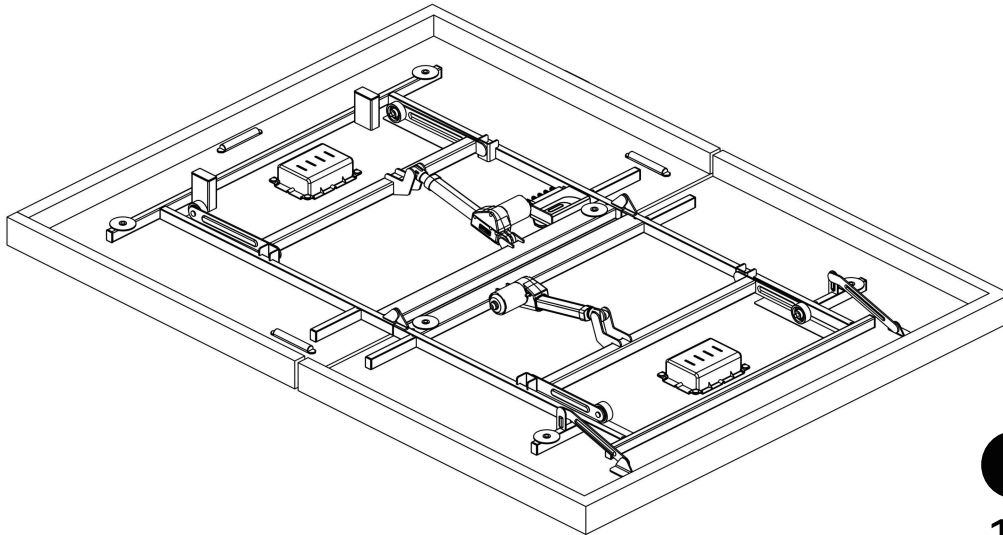

**1**  
1X



**A**  
6X

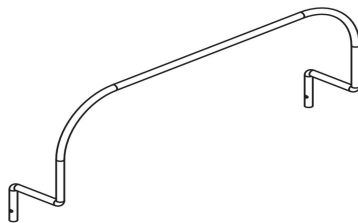

**B**  
1X

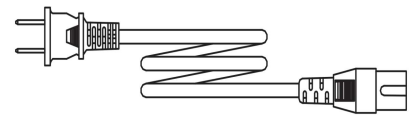

**C**  
1X

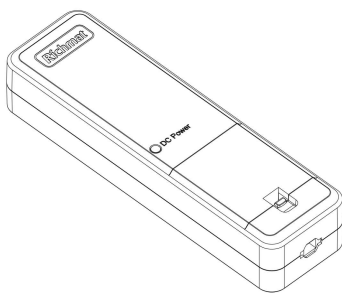

**D**  
1X

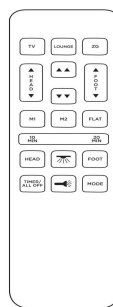

**E**  
1X



**F**  
2X

# STEP 1

Carefully lift the folded base out of the carton and put it flat on the floor.

Remove all packaging and parts from the underside of the bed and confirm that all parts listed are present.

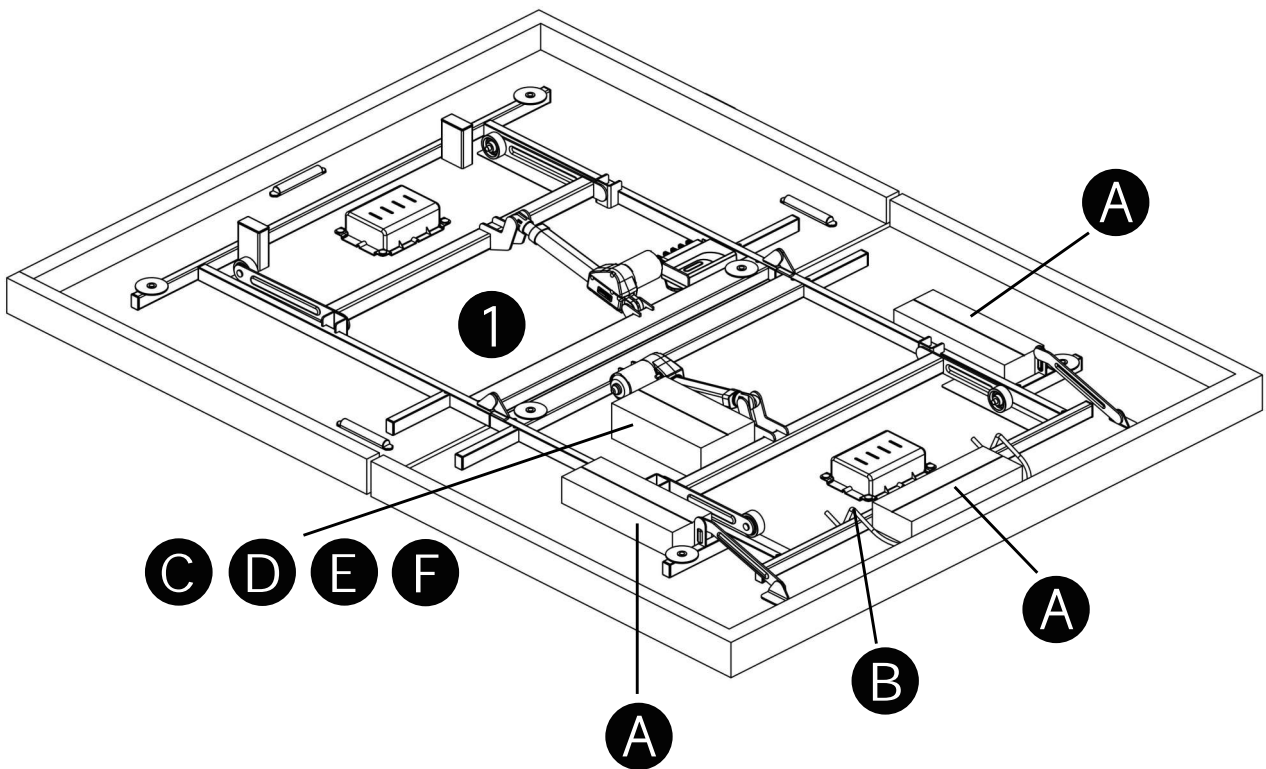

## STEP 2

Install the six legs firmly into the base of the frame. Do not over tighten.

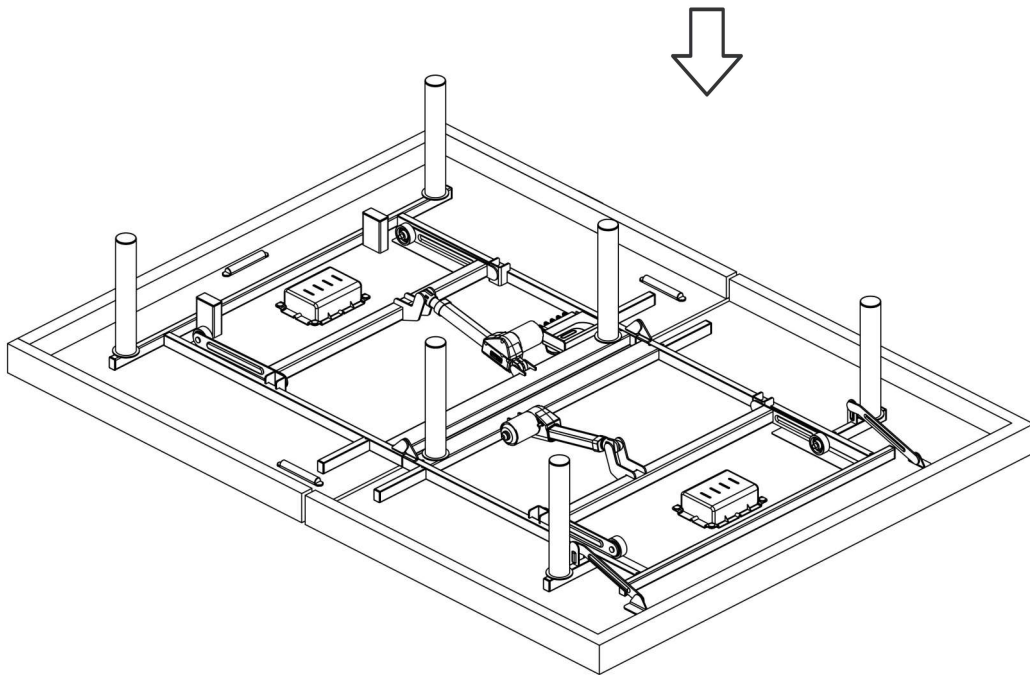
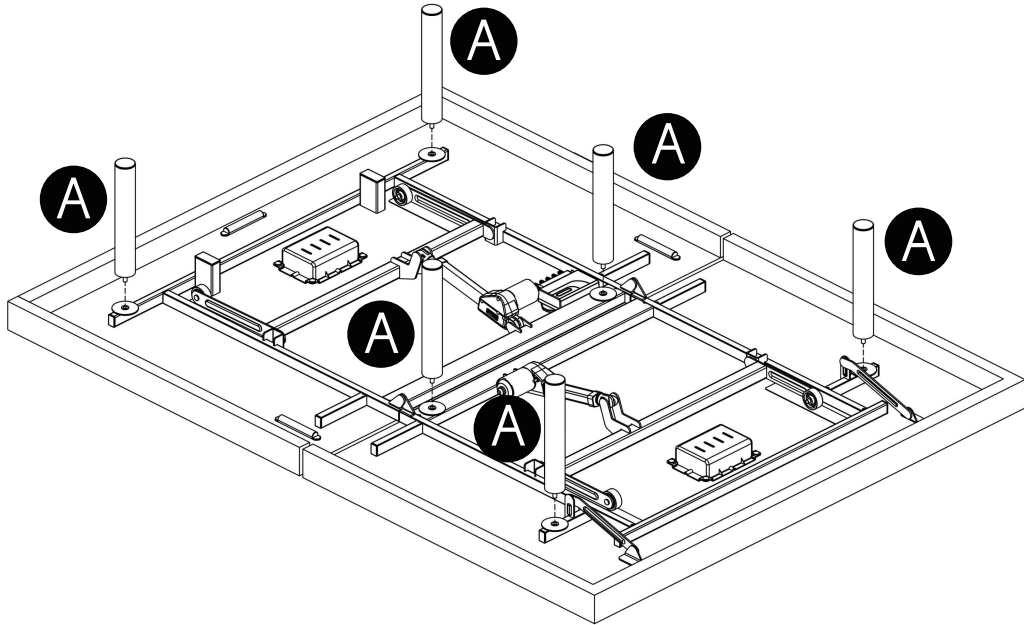

## STEP 3

For safety reasons, lifting of the adjustable bed frame must be performed by two (2) people; should always be in a flat position before operation. Excessive pressure may damage the legs. Remove all protective plastic covering.

**NOTE:** Check to make sure that all power cords are clear and do not interfere with any Adjustable Bed Mechanisms.

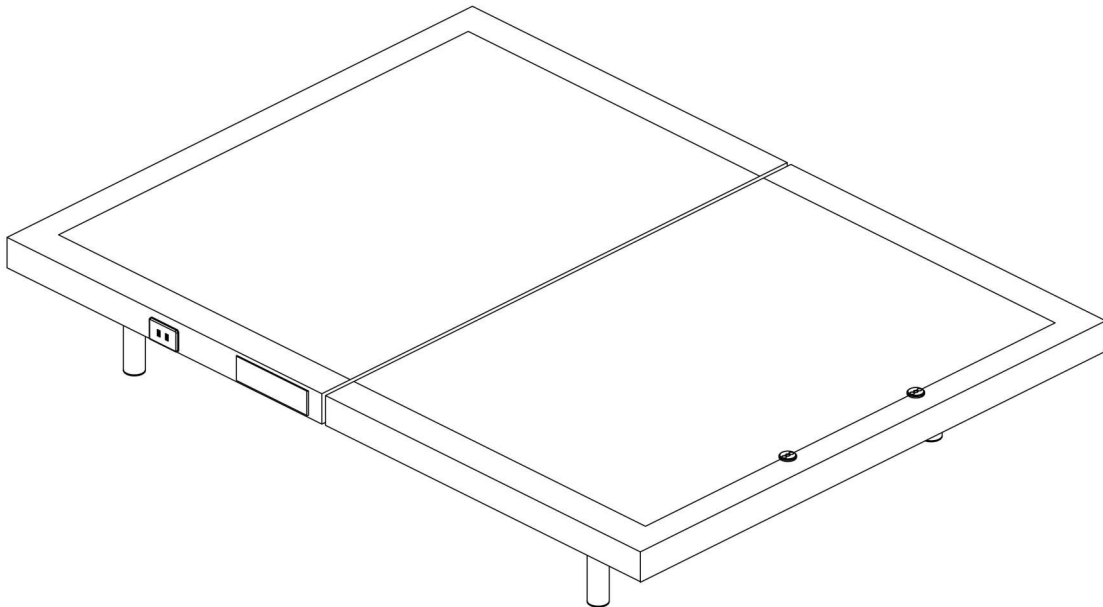

## STEP 4

Get the mattress retainer bar from packaging. Carefully insert the mattress retainer bar into 2 holes on the foot end of bed base.

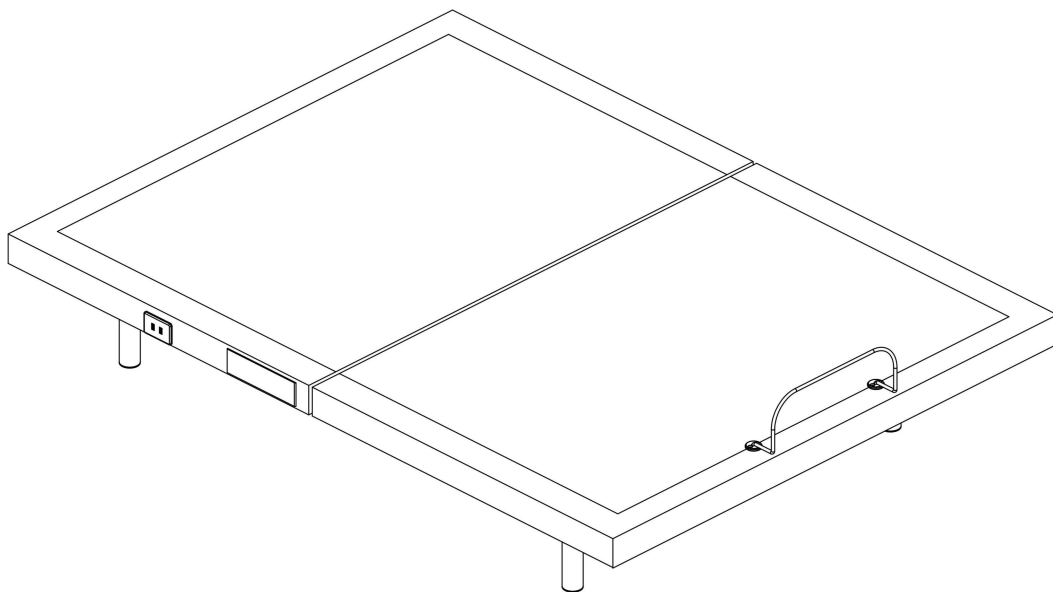
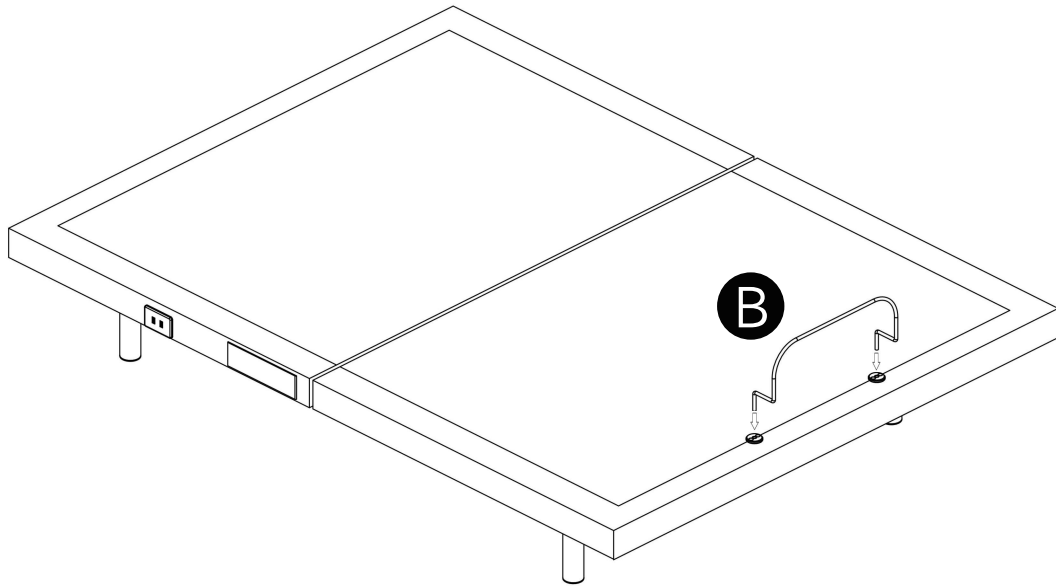

## STEP 5

Extend the input power cord and plug it into the transformer power supply. Connect the transformer power supply to the control box. The control box is the black box attached to the bottom of the bed.

Plug in the adjustable base. You are ready to enjoy!

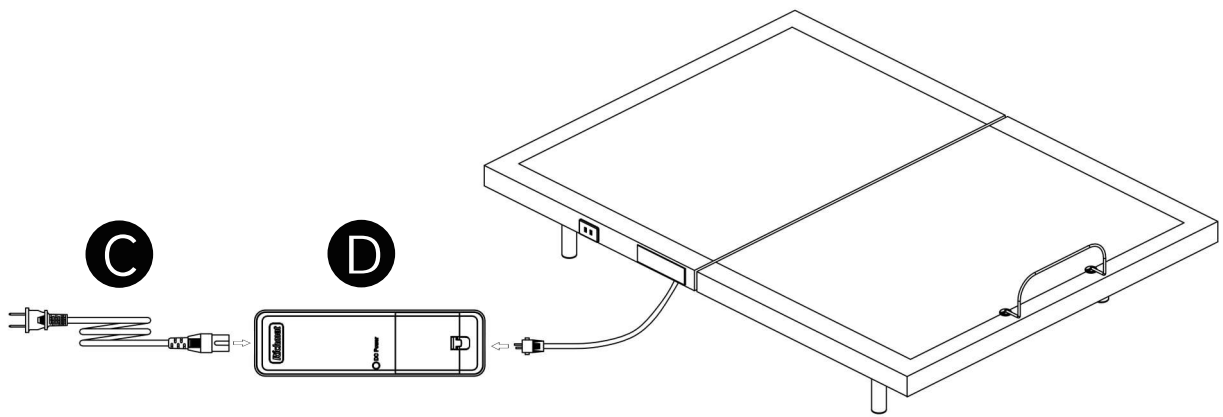

# PAIRING REMOTE

The remote comes paired to the bed. If the remote becomes unpaired, do the following to pair the remote:

First, make sure batteries are in the remote control.

1. Press and hold the **"Adjust Head up"** and **"Adjust Foot up"** buttons.
2. Press and hold the pairing button underneath the bed. The pairing button is on the wire attached to the power supply.
3. Two beeps will sound to indicate a successful pairing.

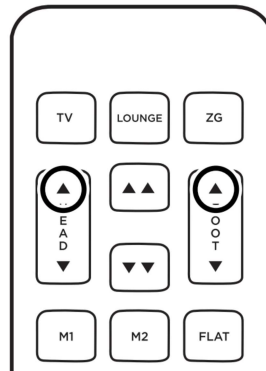
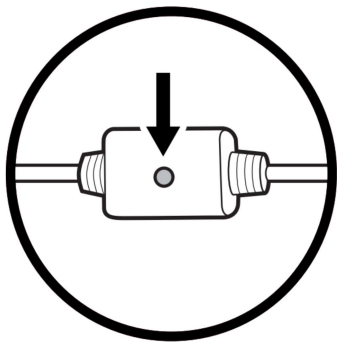

# SETTING PROGRAMMABLE POSITIONS

**NOTE:** M1 and M2 buttons do not come programmed. Each button must be individually programmed before use.

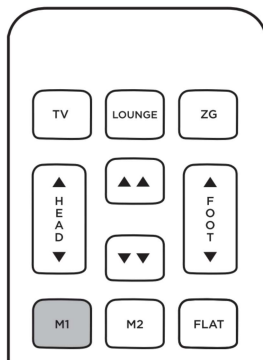

PRESET 1

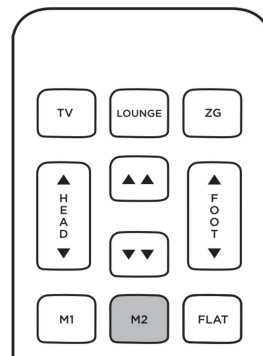

PRESET 2

1. Adjust the bed to your desired position.
2. Press and hold the appropriate memory programmable button for 3-5 seconds.
3. Buttons will flash to indicate the position has been saved.
4. If desired, repeat to set the other memory programmable buttons.

# UNPAIRING

1. Remove the battery from the remote control.
2. Press and hold the **"head up"** and **"foot up"** buttons, then reinstall the batteries. Continue to press the two buttons.
3. Continue to hold for at least five seconds until the light on top of the remote will flash to indicate the remote is unpaired.

# REMOTE CONTROL GUIDE

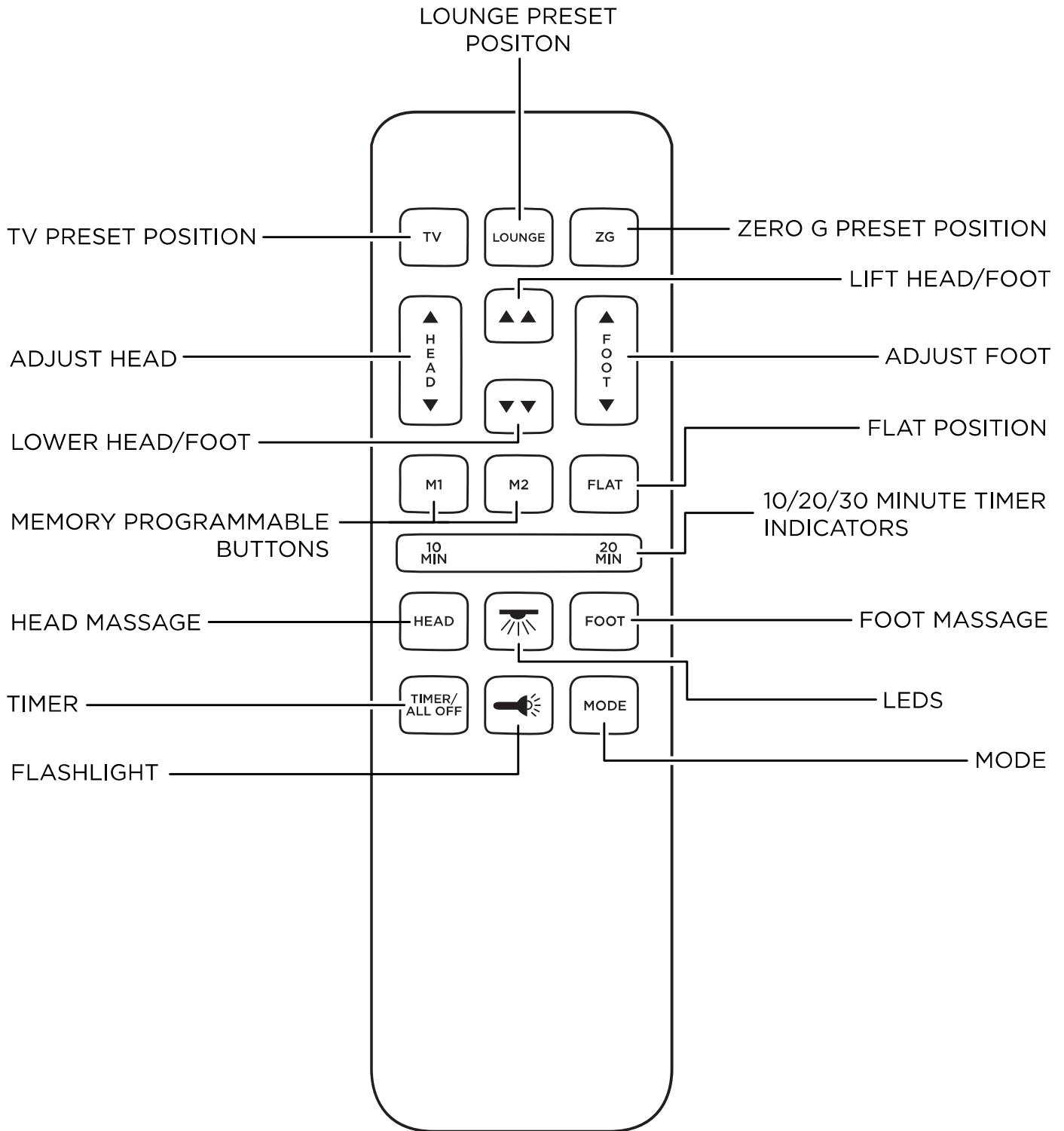

# TROUBLESHOOTING

SYMPTOMS	SOLUTIONS
<p>The base does not respond when the remote is used. Remote LED illuminates and appears to be normal.</p>	<p>Perform any or all of the following:</p> <ul style="list-style-type: none"> <li>*Check that the power cord is plugged into a working and grounded electrical outlet.</li> <li>*Check that the light on the control box is On.</li> <li>*Check the home circuit Breaker and Fuses.</li> <li>*Unplug the power cord from the outlet. After a minute, plug it back in. Press any button on the remote. The base should be working.</li> </ul>
<p>The remote does not work or light up.</p>	<p>Check the remote LED Light is lighting up when pressed. If not, please replace 2*1.5V batteries.</p>
<p>Battery Backup when power failure.</p>	<p>You must purchase 2*9V batteries and install them in the AC/DC adapter on the Power Unit. This functions as a battery backup, which will allow the base to adjust to the flat position, press the Flat button on the remote to get the bed flat.</p>
<p>Base stutters while in motion.</p>	<ul style="list-style-type: none"> <li>*Clear any clutter or obstructions under and around the adjustable base. Radio frequency interference from other remotes or electronic devices may affect normal operation.</li> <li>*Check batteries in remote.</li> <li>*Assure the keys on remote are being pressed firmly down when operating the Head and Foot buttons.</li> </ul>
<p>Massage Motor/s Seems Excessively Loud During Operation. (If have massage function)</p>	<ul style="list-style-type: none"> <li>*Tighten up the massage motor/s to the adjustable base.</li> <li>*Hard surface flooring may cause added vibration. Place a carpet pieces or rubber furniture cups under each leg or caster of the bed.</li> <li>*Check that the bed is not in direct contact with a wall, nightstand, or other object that may cause vibration or noise.</li> <li>*If adjustable base is installed on top of a bed frame, check that the massage motors are not causing bed frame (or bed frame components) to vibrate or rattle.</li> <li>*If a headboard is utilized, please check that the attachment hardware is tightened firmly.</li> </ul>
<p>The massage motor does not work. (If have massage function)</p>	<p>Please ensure all the cords inserted properly. If the massage motor still does not work, the massage unit needs to be replaced.</p> <ul style="list-style-type: none"> <li>*Remove the massage rubber pad. Remove the massage motor and replace a new one.</li> <li>*Cover the rubber pad again and insert the cord to the control box.</li> <li>*Press Massage button to try if it works or not.</li> </ul>